

# INFRASTRUCTURE MANAGEMENT SERVICES

RELIABLE • ROBUST • SECURE

Efficiently manage your IT infrastructure to service evolving business needs. Reliable,  
Robust & Secure Infrastructure Management Services



# INTRODUCTION

IT Infrastructure is the backbone of any organization for business continuity and business growth. Yet, the IT Infrastructure budget and costs are often scrutinized to achieve optimization and cost reductions. The present economic scenario continues to dictate its own pressures – budgetary concerns, in addition to an expectation of improved services, swift response to requirements and reduced Total Cost of Ownership (TCO). The biggest challenge CIOs and CTOs possibly face today is in providing high quality service and integrating latest technology at minimal costs.

In such a challenging environment, Infrastructure Management enables businesses to offload their IT operations to a specialist service provider like Micropro. As a preferred partner for outsourcing IT support requirements, Micropro provides high quality, end-to-end IT infrastructure solutions that focuses on reducing TCO, improving IT infrastructure performance and increasing flexibility, to keep up with evolving business demand and changing needs.

At Micropro, we understand the challenges and how these challenges can be resolved. Our infrastructure services help enterprises design, build and manage their IT infrastructure services in an agile manner. Our robust set of mature offerings is managed by a comprehensive enterprise management framework, which is made available through a flexible engagement model.

## NEED FOR IT INFRASTRUCTURE SERVICES

- Reduced total cost of ownership, better control over IT expenditure.
- Improved flexibility and scalability - resource pool available as per immediate ramp up and ramp down.
- Operational excellence - 100% utilization of resources.
- User experience - 24X7 supports, SPOC (Single Point of Contact).
- Reputable transparency & flexibility.
- Flexible engagement models are designed to bridge the gaps in your IT support, with state-of-the-art infrastructure management tools and practices.
- Our services range from planning to deployment along with ongoing technical support anytime, anywhere.

## OUR APPROACH:

### IMS DELIVERY METHODOLOGY



### ENGAGEMENT DELIVERY MODEL

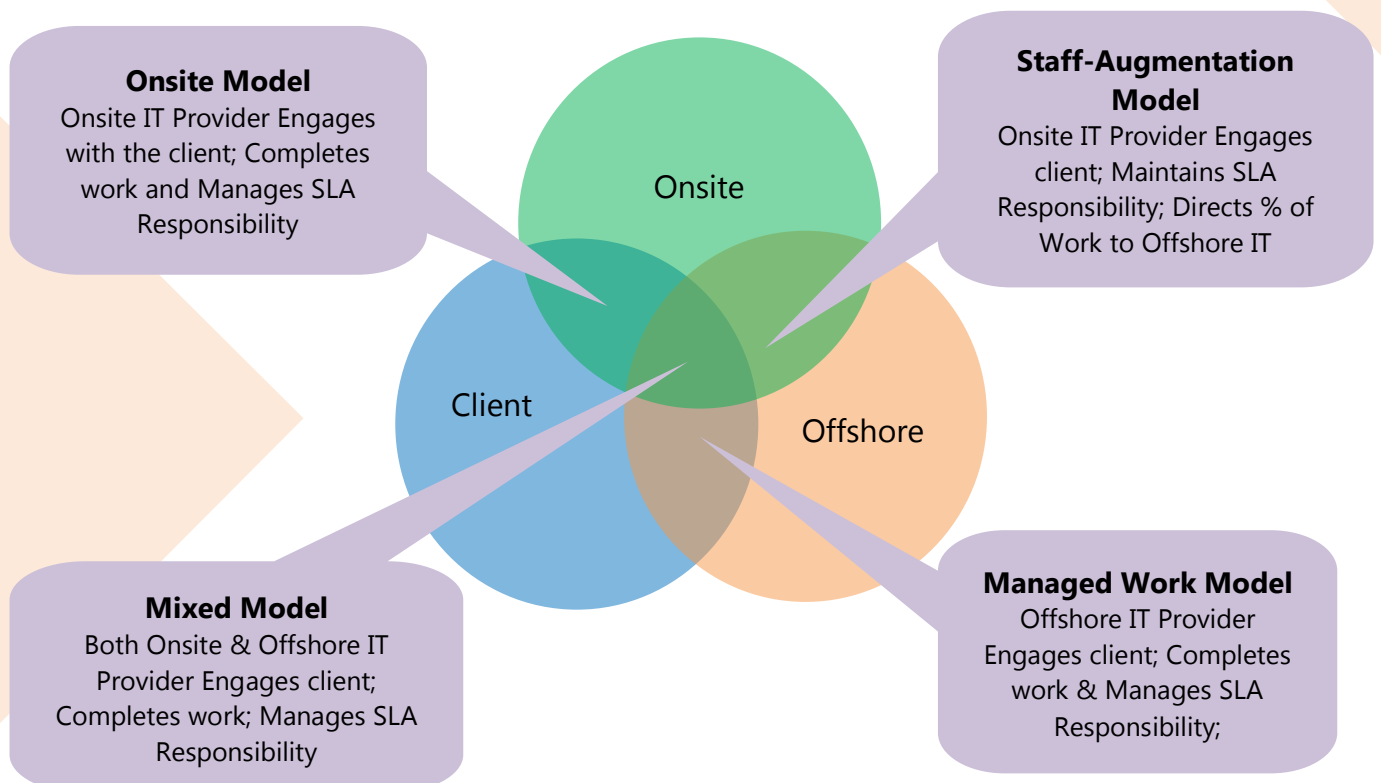

# IT INFRASTRUCTURE SERVICES PORTFOLIO:

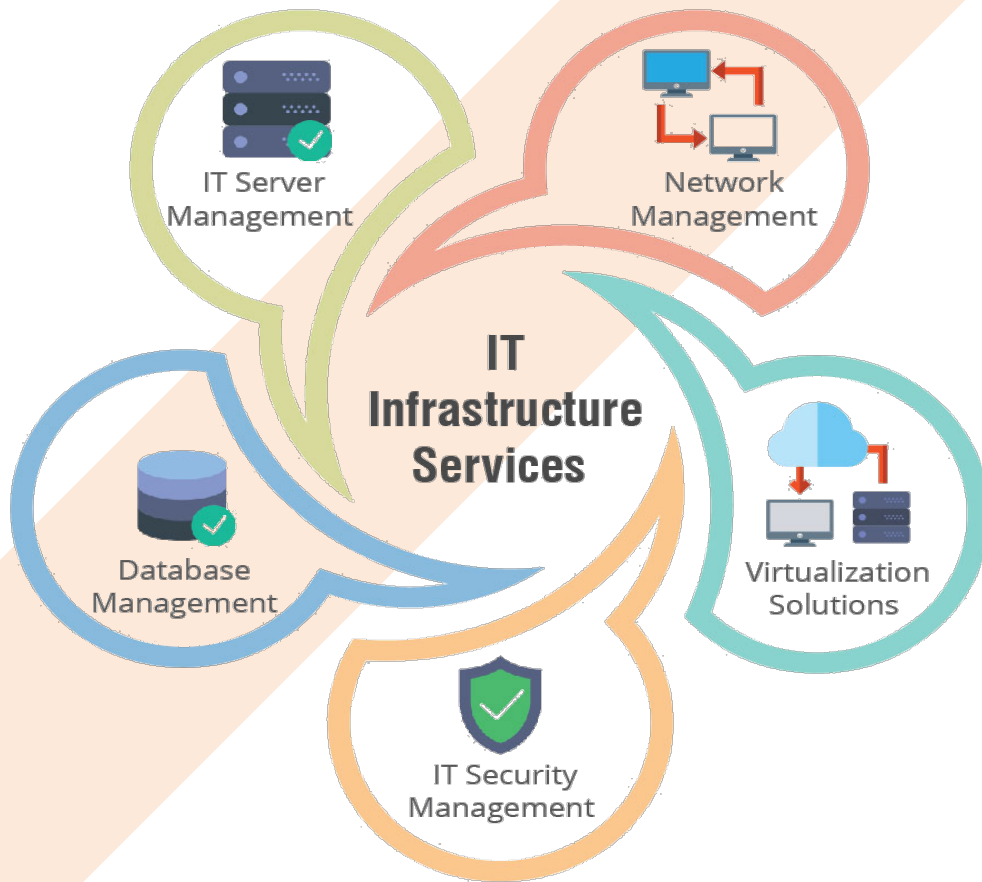



## IT INFRASTRUCTURE SERVICES PORTFOLIO:

### IT INFRASTRUCTURE SERVICES-

- IT SERVER MANAGEMENT
- NETWORK MANAGEMENT
- VIRTUALIZATION SOLUTIONS
- IT SECURITY MANAGEMENT
- DATABASE MANAGEMENT
  
- APPLICATION DEVELOPMENT AND MAINTENANCE SERVICES
  
- APPLICATION MIGRATION SERVICES
- Open Source Services
  
- Remote Infrastructure Management Services



### SERVER MANAGEMENT

The performance of critical infrastructure is essential for business productivity and customer satisfaction in any organization, but managing servers is a costly and time consuming activity. Micropro's Server Management Service ensures availability of server hardware and OS in a healthy and optimal functional state. It refers to the management of daily operations of Servers, making use of technology and best practices, and ensuring businesses stay current while reducing costs.

#### Service Coverage

- Server Hardware and Operating System
- Installation, configuration and administration
- Server Monitoring
- Incident and Problem Management
- Version Migration and Up gradation
- Patch Management

- Performance and capacity management
- Remote branch server administration



## VIRTUALIZATION SERVICES

Micropro's Virtualization Services enable organizations successfully transition from a physical to virtual environment by leveraging our consulting expertise and applying best practices that address the entire virtualization adoption lifecycle. Virtualization technology has proved to be reliable in terms of enabling organizations respond to evolving business needs in a cost effective and timely manner. Management of virtualized infrastructure requires specific skills and the experience which Micropro has acquired through its clientele that spans various industry verticals

### Service Coverage

- Consulting and deployment of Virtualization Technologies and Private Cloud Infrastructure
- Deployment and management of high availability setup
- Administration of Virtual Machines
- SLA based Incident, Problem and Change Management

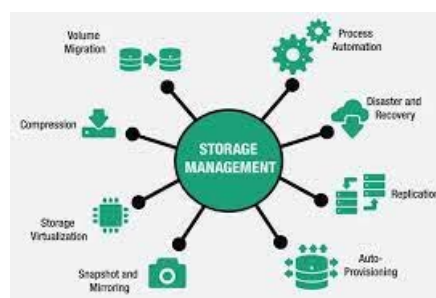

## STORAGE MANAGEMENT

Most organizations find managing increasing amount of data efficiently as a major challenge. A Managed Services Partner for Storage and Backup like Micropro not only manages clients current infrastructure efficiently but also provides key inputs on data usage and suggests measures to control Storage and Backup costs, while

ensuring data availability based on business criticality. With decades of experience in Storage and Backup Management, Micropro is a preferred partner in the industry.

### **Service Coverage**

- Provisioning of Storage
- Monitoring and Management of Storage Infrastructure
- Availability and Capacity Management
- Backup monitoring and restoration testing
- DR Management



### **NETWORK MANAGEMENT**

Today's businesses require seamless functioning of operations that go beyond geographic boundaries and there is high dependency on networking to achieve this. Micropro's Network Infrastructure Management Services address all networking needs and provides reliable and flexible networking infrastructure support to adapt to ever evolving business conditions. We have designed our network management services to provide round-the-clock, reliable and optimally performing networks. By monitoring and managing network installations, Micropro helps it's clients to improve network availability, optimize network performance and proactively manage operational issues to ensure smooth, uninterrupted functionality of the network 24/7.

### **Service Coverage**

- Network consultancy
- Requirement study & Network design
- Network Implementation – LAN/ WAN
- Network Monitoring
- Remote Administration & configuration management of network equipment



- Support services for remote users
- Customer Network Operating Centre (NOC) operations
- Telecoms Management



## SECURITY MANAGEMENT

The ever-changing security threats organizations face today require stringent regulatory compliance requirements within limited internal security budget and resources. Micropro's Information Security and Risk Management can help organizations define a risk-based security strategy aligned to their business needs, implement and manage security solutions aligned to technology trends and ensure compliance levels aligned to regulatory environment. Our Managed Security Services offer best in class security expertise and infrastructure while enabling organizations to optimize their security budget.

### Service Coverage

#### 24x7x365 Security Monitoring

- Log Management
- Security Event Monitoring

#### Security Assessment & Vulnerability Management

- Penetration Testing

#### Managed Security Services

- SIEM for malicious activities
- EDR for threat detection

#### Network Security

- Monitoring Firewall, Routers, Switches

## DATABASE MANAGEMENT



Micropro offers comprehensive Database Management Services for industry leading database technologies. We provide these services by leveraging the use of tools, technology and processes along with our in-depth technical knowledge, wide experience and use of best practices across industry verticals.

### Offerings

- Database Deployment
- Database Upgrade
- Database cross platform Migration
- Database consolidation
- Database Managed Services
- Backup & Recovery strategies
- Database Performance Tuning
- Database clustering services
- Database security management
- Database outages and failures detection
- Database auditing
- Disaster and recovery planning
- Database growth and capacity planning

## APPLICATION DEVELOPMENT AND MAINTENANCE SERVICES-



Shift to cloud, the need for digitization and changing customer preferences – has made it essential for organizations to ensure that business applications remain updated not only in terms of technology but also when it comes to features, functionalities and customer experience.

Micropro’s technical and consulting capabilities coupled with deep domain knowledge ensures that our clients get access to next-gen and future ready applications.

Micropro’s team of experts and consultants with their deep knowledge of Application Development technologies and experience of going go-live with business-critical applications for small, medium and large enterprises and help them meet their strategic business goals.

# What Micropro Offers

## Web application Development



## Web Application Development

- Provide Services in all phases of the Application Lifecycle.
- Broad portfolio of Application Development and Maintenance services
- Blend of business expertise and technical knowledge with clear client insights
- We develop perfectly built solutions to optimize value for our customers' businesses.
- Usage of well-designed and robust set of frameworks and methodologies.
- Technology landscape for Development – Java, Php, Python, Django, Angular JS, Nod JS

## Mobile Application Development-



## MOBILE APP DEVELOPMENT

- Design, Develop and Deliver mobile Apps in Android and iOS Platforms
- Native and Hybrid Mobile Apps
- Adherence to all quality standards set by App Stores of Apple and Google.
- Applications built using latest versions making it responsive design and interface

# APPLICATION MIGRATION SERVICES-



MICROPRO SOFTWARE SOLUTIONS PVT LTD. (MPSSPL), is a leading and professional application migration service provider. We support national and international clients for their small to large projects in optimizing basic to complex applications. We have dedicated resources and staff available to support you in each level of application migration. Our team has strong knowledge of application installation, migration, management and maintenance. The application migration team at MPSSPL comprises of highly skilled, trained and qualified software developers and engineers.

## OFFERINGS-

### *TYPES OF APPLICATION MIGRATION SERVICES OFFERED BY MPSSPL-*

- Software Infrastructure deployment and installation
- Application upgradation and management
- Application migration and optimization
- Redesigning, restructuring and re-engineering existing applications
- Integrating and migrating data from various database or web platforms
- Training, supporting and consulting services for application migration



## Open Source Services-

Micropro helps clients replace proprietary technologies with Open Source to deliver guaranteed lower application costs and greater independence.

Today, organizations are rapidly adopting Open Source technology to quickly develop rich software functions, drive operational effectiveness and eliminate the total cost of ownership. Open Source offers a low total Cost of Ownership along with which other advantages such as reliability, security, flexibility in development and deployment of customizable business solutions and improved software quality.

Micropro helps organizations take full advantage of open source and the value they derive from it. We specialize in managing end to end infrastructure solutions. The benefit of letting us do this is that it allows you to focus on your core business while letting us focus on managing the infrastructure, which is our core expertise.

## What we offer-

- **Technology evaluation and recommendation**

We evaluate your infrastructure and help you choose the right open source platform.

- **Security and vulnerability assessment**

Strengthen defense, mitigate new risks to maintain business continuity and reputation with IT security audit and vulnerability services.

- **Cross Platform migration**

We help in cross platform migration like migration from Linux to Unix to improve your organizational functionality.

- **Software change management**

Software change management is the process of selecting which changes to encourage, which to allow, and which to prevent, according to project criteria such as schedule and cost.

- **Cloud/Hybrid Solution**

Scale your organization, improve efficiency, flexibility and maintain business continuity with cloud solutions.

# REMOTE INFRASTRUCTURE MANAGEMENT SERVICES



Organizations have realized the value of remote IT infrastructure management. The industry as a whole has witnessed high growth in the adoption of Remote Infrastructure Management (RIM). RIM is a mission-critical service and reflects high customer confidence and relationship.

Micropro is a preferred RIM service provider and has experience in managing IT infrastructure confidently to ensure cost benefits. We deliver Remote Infrastructure Management Services through our state-of-the-art Infrastructure Operations Management Center in Nagpur, which are highly automated and capable of providing Business SLAs and End User SLAs, irrespective of the underlying technology, device or platform.

## Service Coverage

- Monitoring and Management of:
  - Servers and Virtualized environments
  - Storage and backup
  - Network
  - Security
  - Database
  - Applications
  - End User Infrastructure
  - Mobile Devices
- Service Desk
- Service Level Agreement (SLA) - IT based and Business based SLAs

# CASE STUDY

## Introduction

Octroi is a tax levied on the entry of goods into a municipality or any other specified jurisdiction for use, consumption or sale. Octroi is levied at the time when the goods enter the municipal limits where the goods are to be ultimately sold, used or consumed. Generally, Octroi is borne by the purchaser. Goods in transit are exempted from Octroi.

## Challenges

- Decentralized Architecture hence data had to be updated manually from each Naka database through different channels and in different formats to Central Database
- 24Hrs delay in consolidated reports, which caused issues with 'Rahadari Tax' collection
- Manipulation of the reports due to non-automated reporting system
- No information of Octroi Collection / Transit pass / Escorts on check posts at desired time
- Decentralized data storage
- Non Availability of Real Time data
- Waiting of Vehicle long time at Check Post
- Undervaluation resulting in to less collection of Octroi

## Solution

To overcome all the above mentioned challenges Micropro proposed a centralized architecture with 100% redundancy at application, database and switch level so that the Octroi application keeps running 24x7.

- All Naka Database consist of Naka Export entries & Octroi App Entries.
- All Work Centers enter Octroi Entries through Octroi Application to a central database
- Data from Nakas is replicated to a centralized database at DC to get real-time consolidated reports
- Redundancy for each application server as well as database server to overcome any kind of failure at any given level.
- Data stored in Tape Libraries.

## Proposed Centralized Architecture

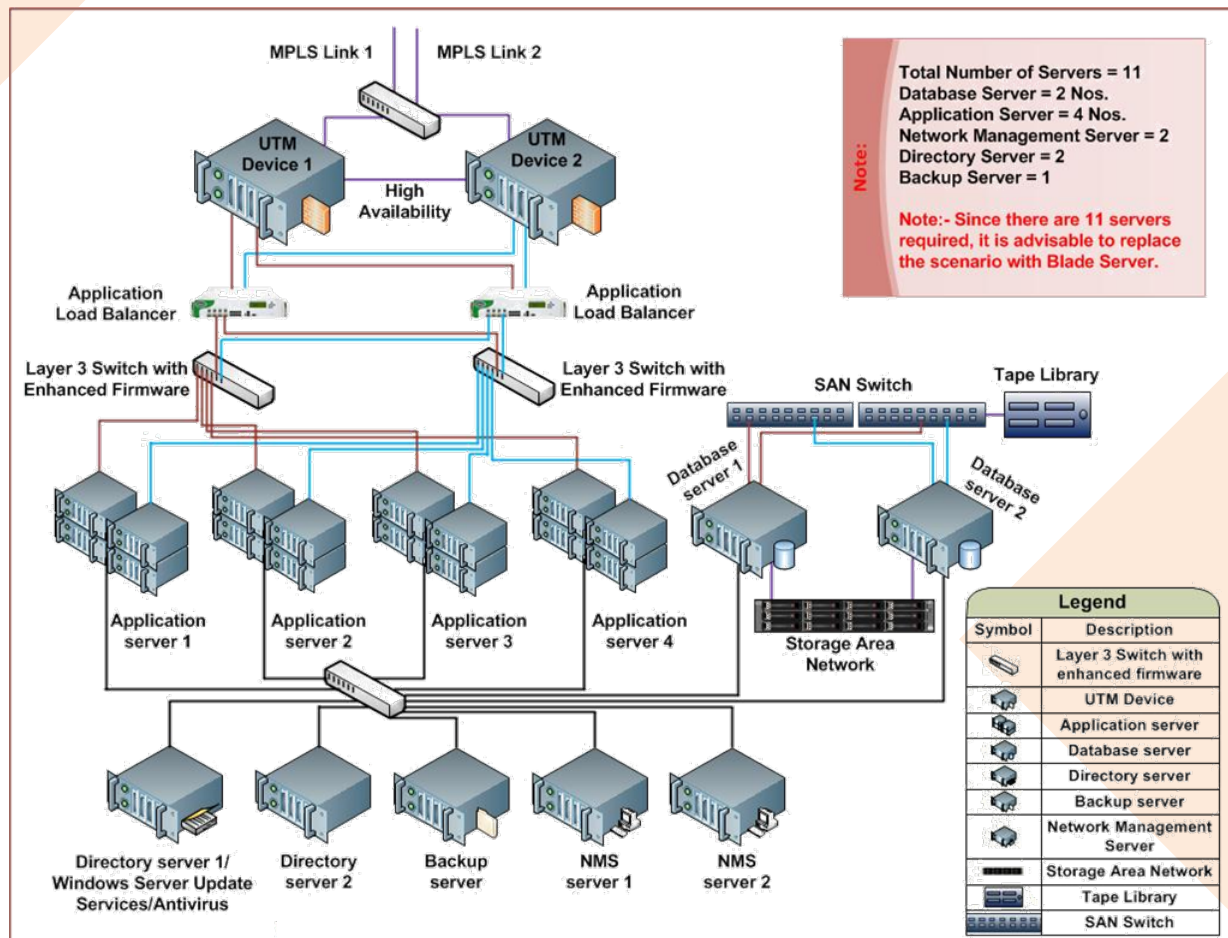

## Benefits



- Consolidation of Data at Central Database in real time with inbuilt Auto-scalability feature
- Consolidated Reports without any delay providing better control on day to day process.
- Real Time report for Audit purpose and Hassel free operation at end points

**INFORMATION TECHNOLOGY IS THE  
BACKBONE OF YOUR ORGANIZATION,  
INTEGRATE INNOVATIVE IT SYSTEMS  
STRENGTHEN YOUR IT INFRASTRUCTURE**

**BUILD RELIABLE, ROBUST AND SECURE  
SYSTEMS**



**CONTACT US**

**HEAD OFFICE:  
INDIA**

28, A WING, 7TH FLOOR,  
IT PARK, GAYATRI NAGAR ROAD,  
NAGPUR - 440022  
MAHARASHTRA INDIA

+91 - 93736 93405  
SALES@MICROPROINDIA.COM

**INTERNATIONAL  
BRANCHES:**

SAIF LOUNGE,  
P.O.BOX 121793  
PHONE: 0505677051 / 0567308505  
EMAIL: VASHTIKAR@MICROPROINDIA.COM



**EMAIL:  
SALES@MICROPROINDIA.COM  
WWW.MICROPROINDIA.COM**